

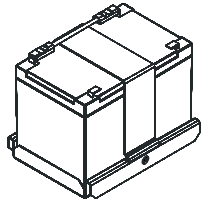

1609 Replacement Battery
 1609 Austausch der Batterie
 Batterie de rechange 1609
 Batería de reemplazo 1609
 Batteria di ricambio 1609
 1609 - Bateria para Substituição

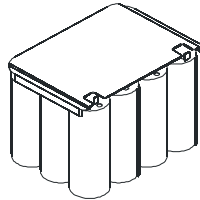



1609-500SBAT
 Standard 40° C Battery





1609-500HBAT
 High Temp 50° C Battery



Anweisungen zur Installation bzw. zum Austausch der Batterie

1. Während des Batterieaustausches muss die USV nicht von der Eingangsstromzufuhr getrennt werden.
2. Tauschen Sie die alte Batterie gegen eine neue Batterie aus.
3. Drücken Sie zum Ausschalten der LED „Batterie austauschen“ den Testschalter, wenn der Ladezustand der Batterie bei über 75 % liegt.
4. Packen Sie die alte Batterie in die Verpackung der Ersatzbatterie und schicken Sie diese an die angegebene Recycling-Adresse.  
5. Batterien nicht mit Feuer in Berührung bringen, da ansonsten Explosionsgefahr besteht. Batterien nicht öffnen oder baulich verändern. Sie enthalten ein giftiges Elektrolyt, das schädlich für Haut und Augen ist. Armbanduhr und Ringe abnehmen, um Verletzungen zu vermeiden. Ausschließlich Werkzeug mit isolierten Griffen verwenden.

Battery Installation/Replacement Instructions

1. It is acceptable to leave the UPS connected to input utility power during the battery replacement procedure.
2. Replace old battery with new battery.
3. To turn off the replace battery LED, press the test button when the battery capacity exceeds 75%.
4. Ship the old battery in the replacement battery packaging to the appropriate recycling address.  
5. Do not expose batteries to fire, they may explode. Do not open or mutilate batteries. They contain an electrolyte that is toxic and is harmful to skin and eyes. To avoid personal injury, remove wrist watches and rings. Use tools with insulated handles.

Instructions d'installation/de remplacement de la batterie

1. Vous pouvez laisser l'onduleur connecté au secteur pendant la procédure de remplacement de la batterie.
2. Remplacez l'ancienne batterie par la nouvelle.
3. Pour éteindre l'indicateur de remplacement de la batterie, appuyez sur le bouton de test lorsque la batterie est chargée à plus de 75 % de sa capacité.
4. Utilisez l'emballage de la batterie de remplacement pour envoyer l'ancienne batterie au centre de recyclage approprié.  
5. N'exposez pas les batteries au feu car elles risquent d'exploser. Ne cherchez pas à ouvrir ou à détruire les batteries. Elles contiennent un électrolyte toxique et dangereux pour les yeux et la peau. Ne portez pas de bracelet-montre ni de bague pour éviter de vous blesser. Utilisez des outils dont les poignées sont isolées.

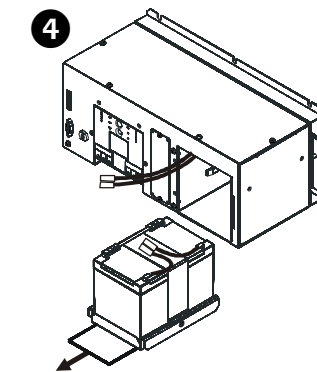
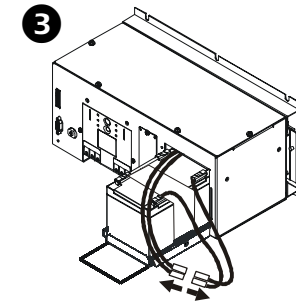
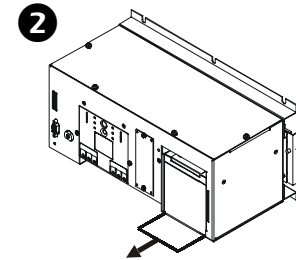
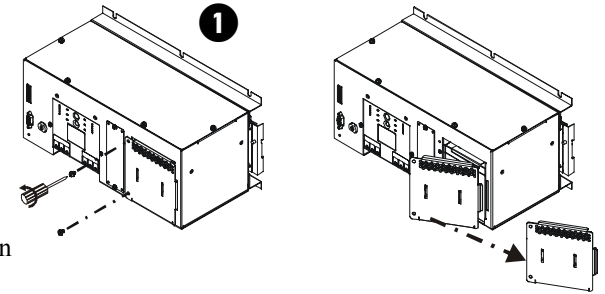



1609 Replacement Battery
 1609 Austausch der Batterie
 Batterie de rechange 1609
 Bateria de reemplazo 1609
 Batteria di ricambio 1609
 1609 - Bateria para Substituição

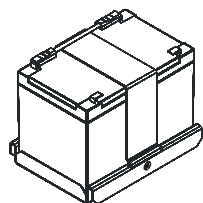

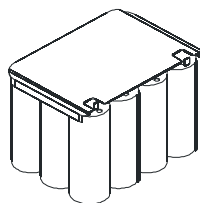

1609-500SBAT
 Standard 40° C Battery





1609-500HBAT
 High Temp 50° C Battery



Istruzioni per l'installazione e la sostituzione della batteria

1. Durante la procedura di sostituzione della batteria è possibile lasciare l'UPS collegato all'alimentazione di rete in entrata.
2. Sostituire la batteria vecchia con una nuova.
3. Per spegnere il LED per la sostituzione della batteria, premere il pulsante di verifica quando la capacità della batteria supera il 75%.
4. Spedire la batteria vecchia nel materiale d'imballo della batteria di ricambio all'indirizzo appropriato per il riciclaggio.  
5. Non esporre le batterie al fuoco perché potrebbero esplodere. Non aprire o alterare le batterie. L'elettrolita in esse contenuto è tossico e pericoloso per la pelle e per gli occhi. Per evitare lesioni personali, togliersi orologi e anelli. Utilizzare utensili con manici isolati.

Instrucciones de instalación/reemplazo de la batería

1. Se puede dejar el SAI conectado al suministro de entrada de energía de la red pública durante el procedimiento de reemplazo de la batería.
2. Reemplace la batería vieja por la nueva.
3. Para apagar el indicador luminoso de reemplazo de la batería, presione el botón de prueba cuando la capacidad de la batería exceda el 75%.
4. Envíe la batería vieja en el embalaje de la batería de reemplazo a la dirección de reciclado correspondiente.  
5. No exponga las baterías al fuego, ya que pueden explotar. No abra ni mutile las baterías. Contienen un electrolito tóxico y perjudicial para la piel y los ojos. Para evitar lesiones personales, quítese los relojes de pulsera y los anillos. Utilice herramientas con mangos aislados.

Instruções para instalação/substituição das baterias

1. É possível deixar o no-break conectado à energia da rede elétrica de entrada durante o procedimento de substituição de bateria.
2. Substitua a bateria antiga pela bateria nova.
3. Para desligar o LED que indica necessidade de substituição de bateria, pressione o botão de teste quando a capacidade da bateria estiver acima de 75%.
4. Envie a bateria antiga na embalagem da bateria usada na substituição para um local de reciclagem adequado.  
5. Não exponha as baterias ao fogo: elas podem explodir. Não abra ou danifique as baterias. Elas contêm um eletrólito que é tóxico e prejudicial à pele e aos olhos. Para evitar acidentes e ferimentos, tire relógios e anéis. Use ferramentas com cabos isolados.

